

SECTION A-A

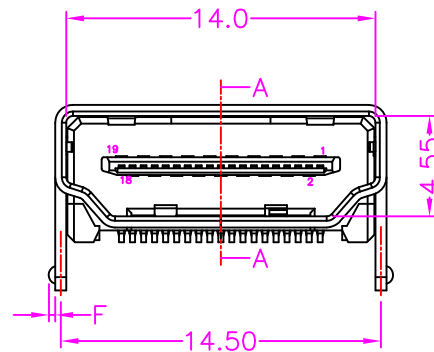

P.C.B LAYOUT TOP VIEW ±0.05

HDMI TYPE A PIN ASSIGNMENT

PIN	Signal Assignment
1	TMDS Data2+
2	TMDS Data2 Shield
3	TMDS Data2-
4	TMDS Data1+
5	TMDS Data1 Shield
6	TMDS Data1-
7	TMDS Data0+
8	TMDS Data0 Shield
9	TMDS Data0-
10	TMDS Clock+
11	TMDS Clock Shield
12	TMDS Clock-
13	CEC
14	Reserved (N.C. on device)
15	SCL
16	SDA
17	DDC/CEC Ground
18	+5V Power
19	Hot Plug Detect

TABLE 1

ITEM	DIM A	DIM B
1	1.80	1.20
2	2.20	1.20
3	1.80	1.00
4	2.20	1.00

TABLE 2

ITEM	DIM. F	DIM. G
1	NON	0.90
2	0.15	0.90
3	0.30	1.10

PART NUMBER:

2HDBA - 1 9 * T - 1 2 3 * * *

SERIES
NO. OF POS.

CONTACT PLATED OPTION

- 1: GOLD FLASH
- 3: 3u" GOLD
- 5: 5u" GOLD
- 7: 15u" GOLD
- 9: 30u" GOLD

MYLAR OPTION
BLANK: WITHOUT MYLAR
M: WITH MYLAR

"F & G" LENGTH OPTION
REF TABLE 2

"A & B" LENGTH OPTION
REF TABLE 1

TAPE REEL PACKAGE

TIN PLATING ON SOLDER TAIL

MATERIALS

HOUSING: HI-TEMP. PLASTIC (UL 94V-0)
SHELL: COPPER ALLOY, NICKEL PLATING
TERMINAL: COPPER ALLOY, GOLD PLATED ON CONTACT AREA
TIN PLATING ON SOLDER TAIL

SPECIFICATION

CURRENT RATING: 0.5 AMP MAX
DIELECTRIC WITHSTANDING: 500V AC FOR ONE MINUTE
CONTACT RESISTANCE: 30m OHMS MAX
INSULATION RESISTANCE: 100M OHMS MIN AT DC 500V
OPERATION TEMPERATURE: -20°C~+85°C

A	RELEASE	2013.4.29
REV.	DESCRIPTION	DATE



Cyberconn Technology Co., Ltd.

www.cyberconn.com.tw

Tel+886-3-4951314

TOLERANCES		HDMI CONNECTOR SERIES					
X.X ±0.3		HDMI, PCB MOUNT, SMT, METAL SHIELD, FEMALE					
X.XX ±0.2		DRAWN BY		CHECKED BY		APPROVED BY	
X.XXX ±0.1		<i>Janice</i>		<i>Lion</i>		<i>Benson</i>	
Angle ±5°		UNIT	SCALE	SIZE	DRAW NO.	REV.	Sheet
		10050	MM	NONE	A4	2HDBA-003	A 1/1