

MATERIALS

HOUSING: PBT (UL 94V-0), BLUE
 SHELL: SPCC, NICKEL PLATING
 BOARD LOCK: SPCC, TIN PLATING
 TERMINAL: COPPER ALLOY, GOLD PLATED ON CONTACT AREA
 TIN PLATING ON SOLDER TAIL

SPECIFICATION

CURRENT RATING: 5 AMP MAX
 DIELECTRIC WITHSTANDING: 1000V AC FOR ONE MINUTE
 CONTACT RESISTANCE: 30m OHMS MAX
 INSULATION RESISTANCE: 1000M OHMS MIN AT DC 500V
 OPERATION TEMPERATURE: -55°C~+105°C

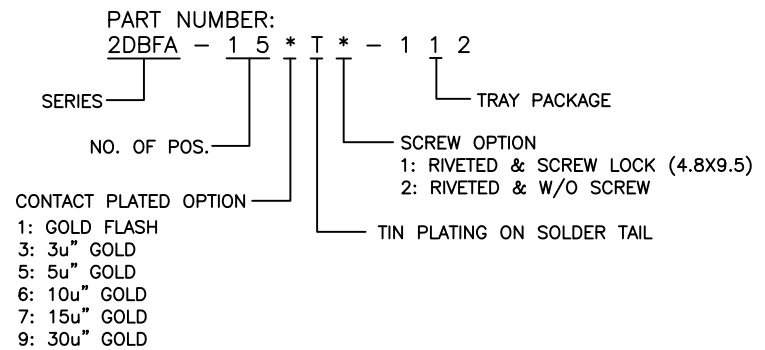

Cyberconn Technology Co., Ltd. www.cyberconn.com.tw Tel:+886-3-4951314						
TOLERANCES		D-SUB CONNECTOR SERIES				
X.X ±0.3		TITLE HIGH DENSITY D-SUB, PCB MOUNT, VERTICAL, METAL SHIELD, FEMALE, STAMPED PIN WITH BOARDLOCK				
X.XX ±0.2		DRAWN BY		CHECKED BY		APPROVED BY
X.XXX ±0.1		Janice		Lion		Benson
Angle ±5°		UNIT	SCALE	SIZE	DRAW NO.	REV. Sheet
		10124	MM	NONE	A4	2DBFA-002 A 1/1

A	RELEASE	2013.7.11
REV.	DESCRIPTION	DATE