

PART NUMBER:
022BM - O * N - 1 * *

CONNECTOR TERMINAL PLATING OPTION
1: GOLD FLASH
3: 3u" GOLD
7: 15u" GOLD

SERIES

TRAY PACKAGE

LOGO OPTION
BLANK: W/O LOGO
L: WITH "CTC" LOGO

LIGHT PIPES OPTION
1: WITH INNER & OUTER LIGHT PIPES
2: WITH OUTER LIGHT PIPES
3: WITH INNER LIGHT PIPES

Cyberconn Technology Co., Ltd.
www.cyberconn.com.tw Tel:+886-3-4951314

TOLERANCES	SFP SERIES				
X.X ±0.3	TITLE STACKED SFP+ 2x2 CAGE, R/A, METAL SHIELD PRESS FIT TYPE WITH CONNECTOR & LIGHT PIPE				
X.XX ±0.2	DRAWN BY	CHECKED BY	APPROVED BY		
X.XXX ±0.1	Janice	Lion	Benson		
Angle ±5°	UNIT	SCALE	SIZE	DRAW NO.	REV.
	10001	MM	NONE	A4	022BM-001
					Sheet
					1/5

A	RELEASE	2012.9.20
REV.	DESCRIPTION	DATE

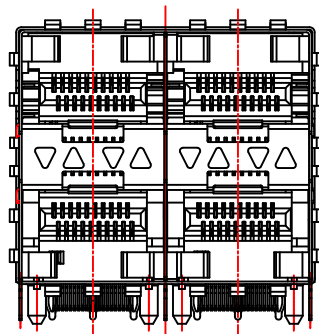

022BM-0*N-11*
WITH INNER & OUTER LIGHT PIPES

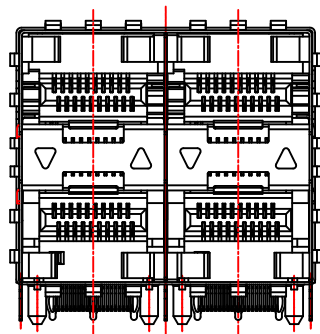

022BM-0*N-12*
WITH OUTER LIGHT PIPES

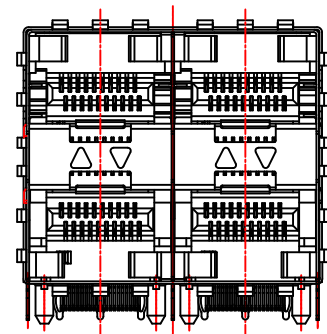

022BM-0*N-13*
WITH INNER LIGHT PIPES

A	RELEASE	2012.9.20
REV.	DESCRIPTION	DATE

Cyberconn Technology Co., Ltd.
www.cyberconn.com.tw Tel:+886-3-4951314

TOLERANCES	SFP SERIES					
X.X ±0.3	TITLE STACKED SFP+ 2x2 CAGE, R/A, METAL SHIELD PRESS FIT TYPE WITH CONNECTOR & LIGHT PIPE					
X.XX ±0.2	DRAWN BY	CHECKED BY		APPROVED BY		
X.XXX ±0.1	<i>Janice</i>	<i>Lion</i>		<i>Benson</i>		
Angle ±5°	UNIT	SCALE	SIZE	DRAW NO.	REV.	Sheet
	10001	MM	NONE	A4	022BM-001	A 2/5

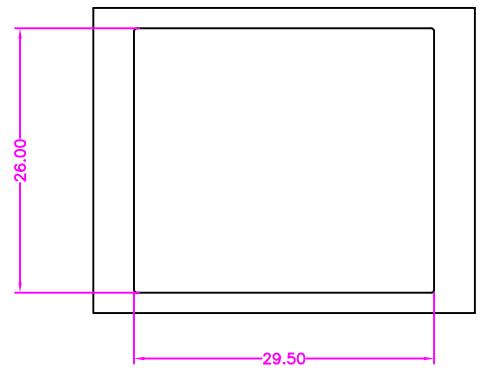

BEZEL CUT-OUT CENTER SPACING DETAIL
BEZEL THICKNESS:0.8-2.6

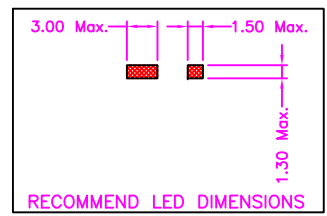
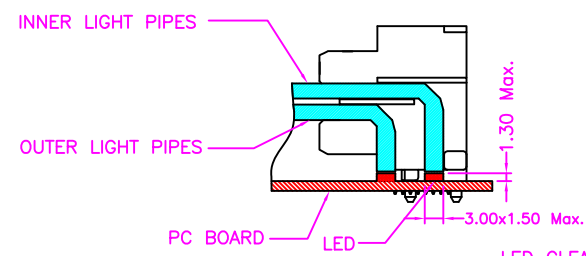
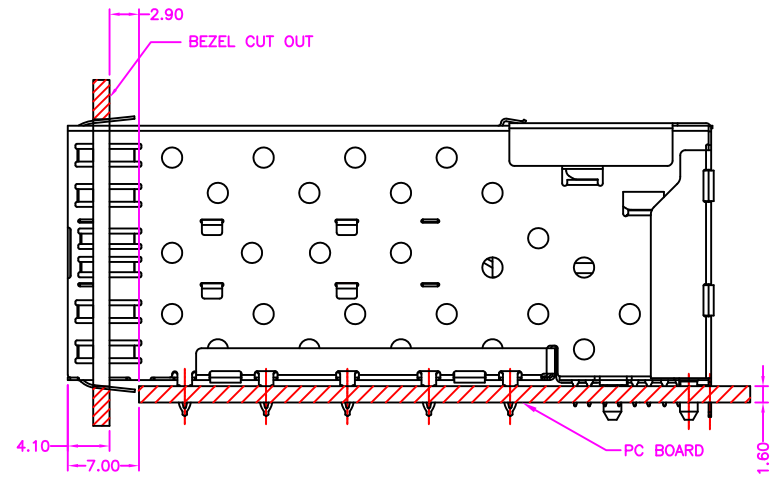

LED CLEARANCE REQUIREMENTS

MATERIALS

- SFP CONNECTOR
- HOUSING: LCP (UL 94V-0), BLACK
- TERMINAL: COPPER ALLOY, GOLD PLATED ON CONTACT AREA
TIN PLATING ON SOLDER TAIL
- SFP CAGE
- TOP SHIELD: COPPER ALLOY, NICKEL PLATING
- MIDDLE SHIELD: SUS, NICKEL PLATING
- BOTTOM SHIELD: COPPER ALLOY, NICKEL PLATING
- BACK SHIELD: COPPER ALLOY, NICKEL PLATING
- BRACKET: COPPER ALLOY, NICKEL PLATING

LIGHT PIPE: PC

Cyberconn Technology Co., Ltd.
www.cyberconn.com.tw Tel:+886-3-4951314

TOLERANCES		SFP SERIES					
X.X ±0.3	TITLE	STACKED SFP+ 2x2 CAGE, R/A, METAL SHIELD PRESS FIT TYPE WITH CONNECTOR & LIGHT PIPE					
X.XX ±0.2		DRAWN BY	CHECKED BY	APPROVED BY			
X.XXX ±0.1		<i>Janice</i>	<i>Lion</i>	<i>Benson</i>			
Angle ±5°		UNIT	SCALE	SIZE	DRAW NO.	REV.	Sheet
10001		MM	NONE	A4	022BM-001	A	3/5

A	RELEASE	2012.9.20
REV.	DESCRIPTION	DATE

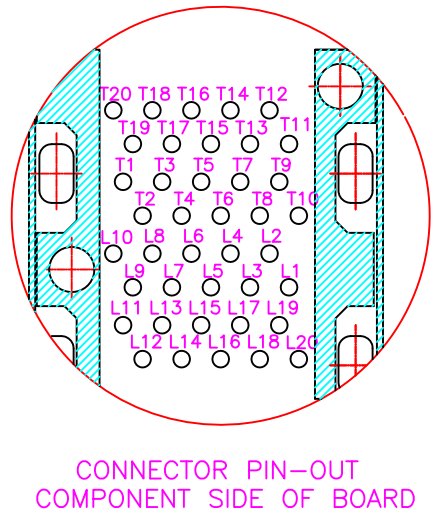
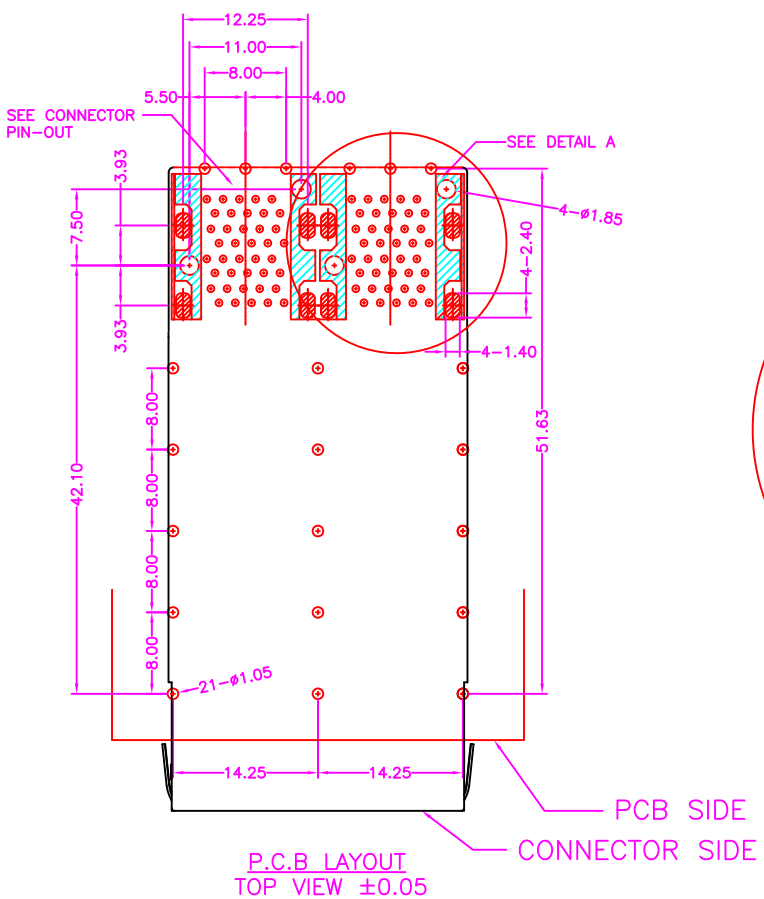
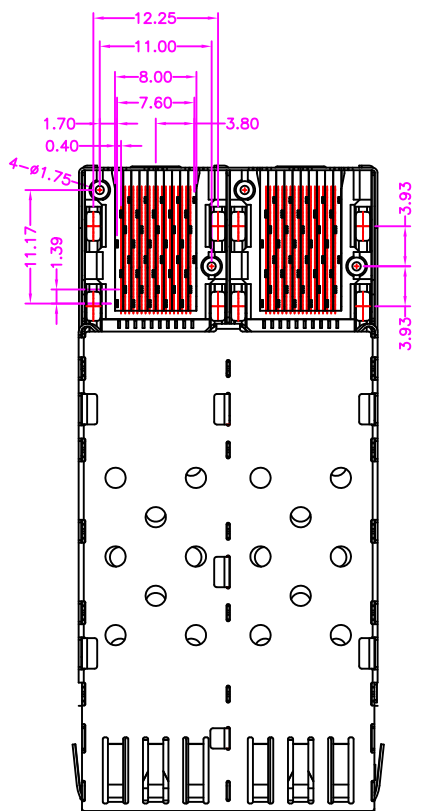

A	RELEASE	2012.9.20
REV.	DESCRIPTION	DATE

Cyberconn Technology Co., Ltd.
www.cyberconn.com.tw Tel:+886-3-4951314

TOLERANCES	SFP SERIES					
X.X ± 0.3	TITLE STACKED SFP+ 2x2 CAGE, R/A, METAL SHIELD PRESS FIT TYPE WITH CONNECTOR & LIGHT PIPE					
X.XX ± 0.2	DRAWN BY		CHECKED BY		APPROVED BY	
X.XXX ± 0.1	<i>Janice</i>		<i>Lion</i>		<i>Benson</i>	
Angle $\pm 5^\circ$	UNIT	SCALE	SIZE	DRAW NO.	REV.	Sheet
	10001	MM	NONE	A4	022BM-001	A 4/5

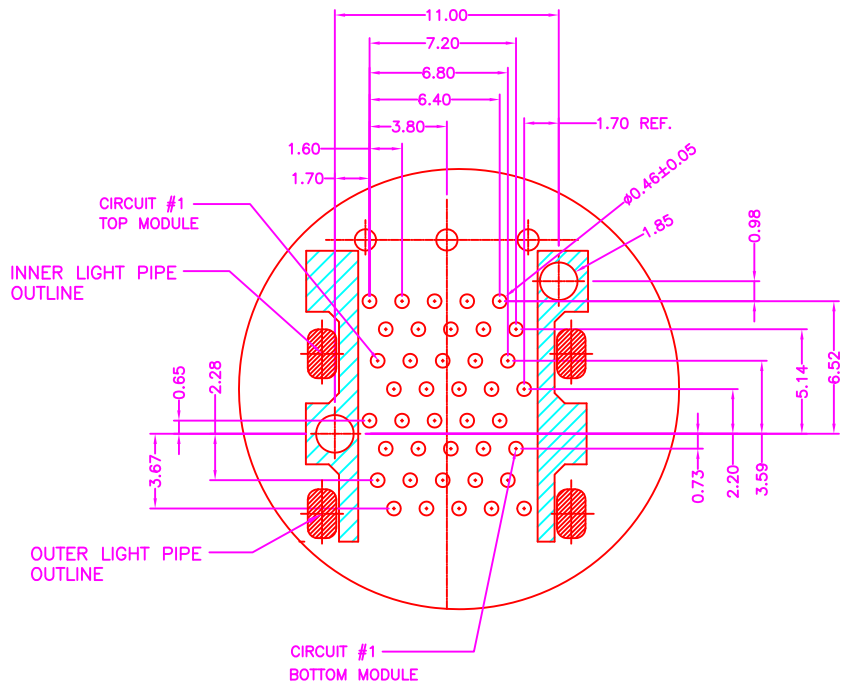

P.C.B. LAYOUT
TOP VIEW ±0.05

DEATIL A
SCALE 2:1

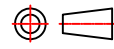
 Cyberconn Technology Co., Ltd. <small>www.cyberconn.com.tw Tel:+886-3-4951314</small>							
TOLERANCES		SFP SERIES					
X.X ±0.3		TITLE STACKED SFP+ 2x2 CAGE, R/A, METAL SHIELD PRESS FIT TYPE WITH CONNECTOR & LIGHT PIPE					
X.XX ±0.2							
X.XXX±0.1		DRAWN BY		CHECKED BY		APPROVED BY	
Angle ±5°		<i>Janice</i>		<i>Lion</i>		<i>Benson</i>	
		UNIT	SCALE	SIZE	DRAW NO.	REV.	Sheet
10001		MM	NONE	A4	022BM-001	A	5/5

A	RELEASE	2012.8.30
REV.	DESCRIPTION	DATE