

DETAIL: A  
SCALE: 2.5:1

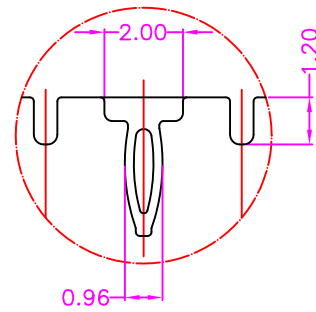

DETAIL: C  
SCALE: 4:1

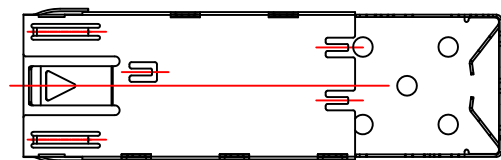
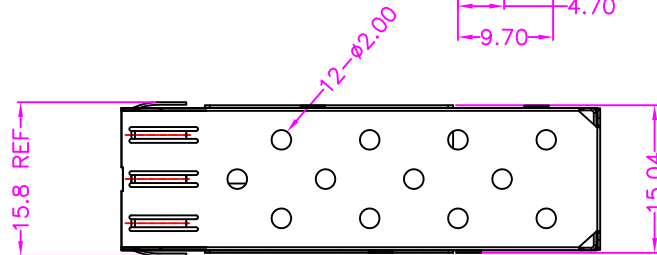
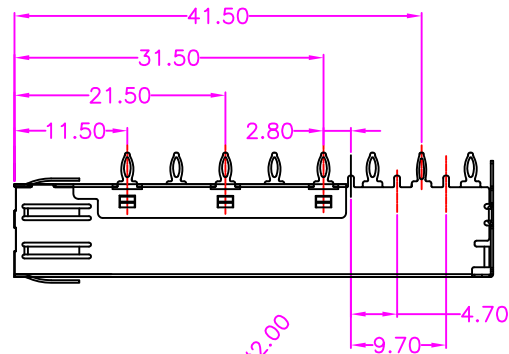
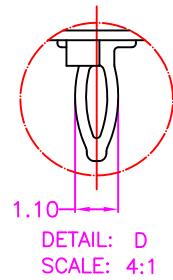

DETAIL: D  
SCALE: 4:1

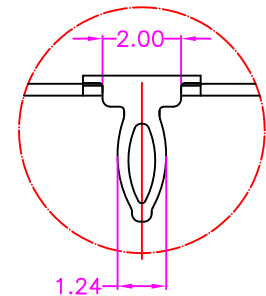

DETAIL:  
SCALE:

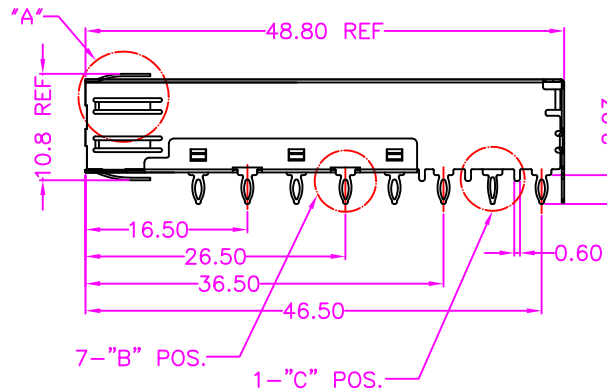
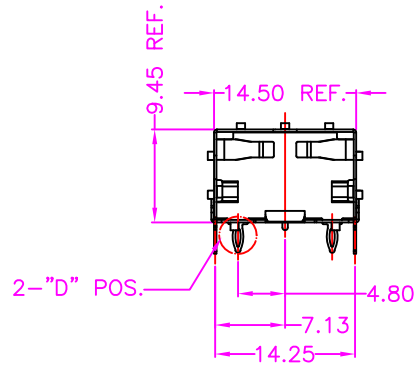

MATERIALS

METAL SHIELD: COPPER ALLOY, NICKEL PLATING

PART NUMBER:

011AC - 0 N - 1 0

SERIES

TRAY PACKAGE

<b>Cyberconn Technology Co., Ltd.</b> <small>www.cyberconn.com.tw Tel.+886-3-4951314</small>						
TOLERANCES		TITLE				
X.X ±0.3		SFP SERIES				
X.XX ±0.2		SFP CAGE, R/A, METAL SHIELD, PRESS FIT TYPE				
X.XXX ±0.1		DRAWN BY		CHECKED BY		APPROVED BY
Angle ±5°		<i>Janice</i>		<i>Lion</i>		<i>Benson</i>
		UNIT	SCALE	SIZE	DRAW NO.	REV. Sheet
		10001	MM	NONE	A4	011AC-001 A 1/1

A	RELEASE	2011.10.6
REV.	DESCRIPTION	DATE

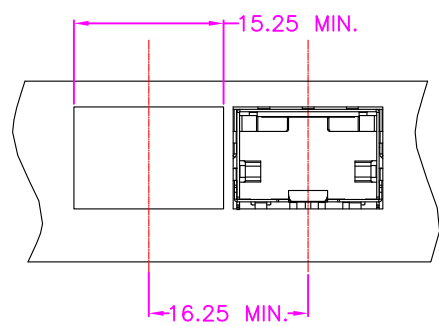

RECOMMENDED PANEL DESIGN

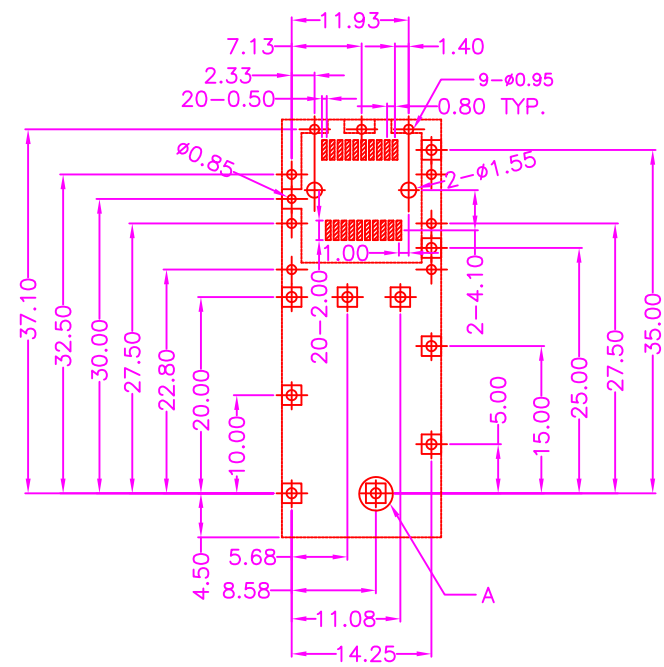
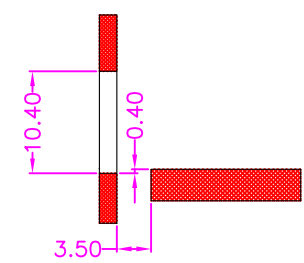

P.C.B LAYOUT  
TOP VIEW ±0.05

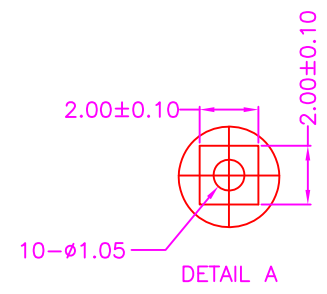

DETAIL A

<b>Cyberconn Technology Co., Ltd.</b> www.cyberconn.com.tw Tel:+886-3-4951314						
TOLERANCES		TITLE				
X.X ±0.3		SFP SERIES				
X.XX ±0.2		SFP CAGE, R/A, METAL SHIELD, PRESS FIT TYPE				
X.XXX ±0.1		DRAWN BY		CHECKED BY		APPROVED BY
Angle ±5°		Janice		Lion		Benson
		UNIT	SCALE	SIZE	DRAW NO.	REV.
10001		MM	NONE	A4	011AC-001-1	A
					Sheet	
					1/1	

A	RELEASE	2011.10.6
REV.	DESCRIPTION	DATE