

1 2 3 4 5 6 7 8

F

F

E

E

D

D

C

C

B

B

A

A

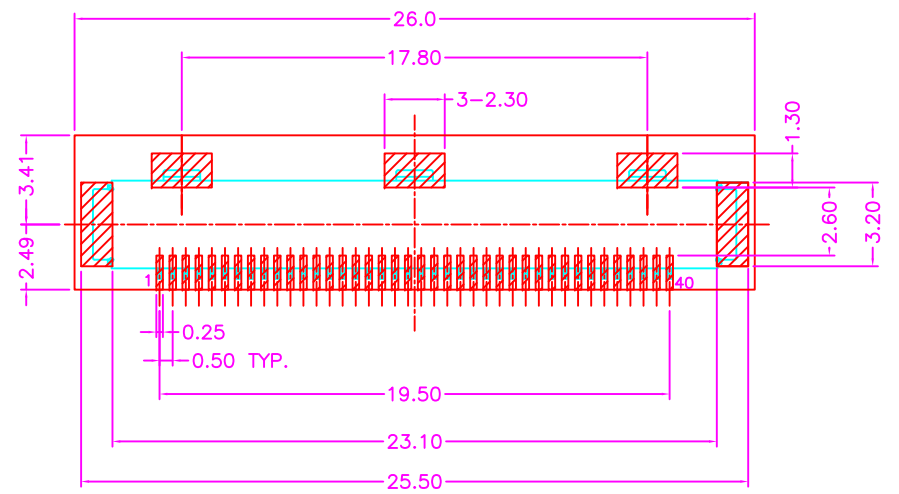
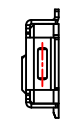
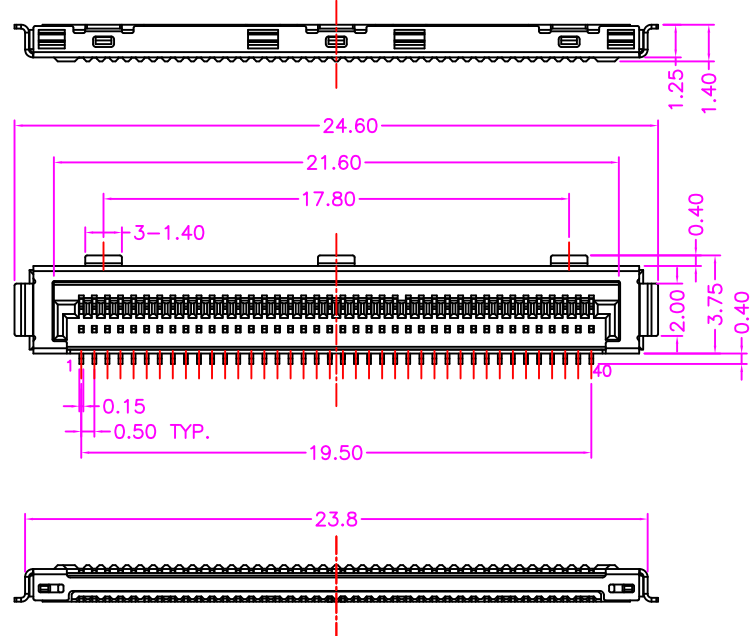

P.C.B. LAYOUT TOP VIEW ±0.05

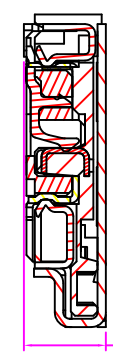
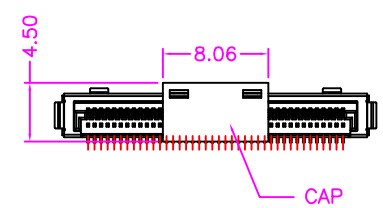

MATERIALS

HOUSING: HI-TEMP. PLASTIC (UL 94V-0)
 CAP: HI-TEMP. PLASTIC (UL 94V-0)
 SHELL: COPPER ALLOY, TIN PLATING
 TERMINAL: COPPER ALLOY, GOLD PLATED

SPECIFICATION

CURRENT RATING: 0.5 AMP MAX
 DIELECTRIC WITHSTANDING: 250V AC FOR ONE MINUTE
 CONTACT RESISTANCE: 40m OHMS MAX
 INSULATION RESISTANCE: 50M OHMS MIN AT DC 500V
 OPERATION TEMPERATURE: -40°C~+85°C

PART NUMBER:

2LVAC - 4 0 * - 2 2 0

SERIES

NO. OF POS.

TAPE REEL PACKAGE

CONTACT PLATED OPTION

- 1: GOLD FLASH
- 3: 3u" GOLD
- 5: 5u" GOLD

Cyberconn Technology Co., Ltd.
 www.cyberconn.com.tw Tel: +886-3-4951314

TOLERANCES X.X ±0.3 X.XX ±0.2 X.XXX ±0.1 Angle ±5°	TITLE	LVDS CONNECTOR SERIES LVDS, 0.50mm PITCH, PCB MOUNT, SMT, METAL SHIELD, MALE, 40PIN				
	DRAWN BY	CHECKED BY	APPROVED BY			
	<i>Janice</i>	<i>Lion</i>	<i>Benson</i>			
	UNIT	SCALE	SIZE	DRAW NO.	REV.	Sheet
10001	MM	NONE	A4	2LVAC-001	A	1/1

A	RELEASE	2011.7.27
REV.	DESCRIPTION	DATE

1 2 3 4 5 6 7 8

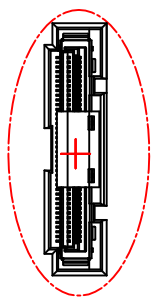
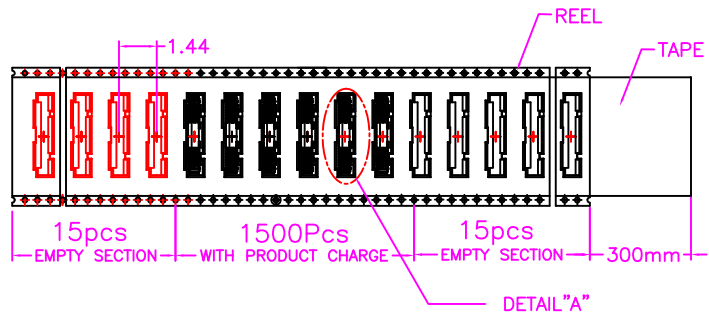

- NOTE:
1. PEELING SPEED: 300mm/MINUTE
 2. PEELING RESISTANCE: 20g~130g
 3. PEELING ANGLE: 165° ~ 180°
 4. DIMENSION:
CARTON (OUTER DIM): L=340, W=340, H=355
 5. QUANTITY:
1500 PCS/REEL
7 PCS REEL/SHIPPING CARTON
 6. WEIGHT:
N.W.:*Kg/REEL,*Kg/CARTON
G.W.:*Kg/REEL,*Kg/CARTON

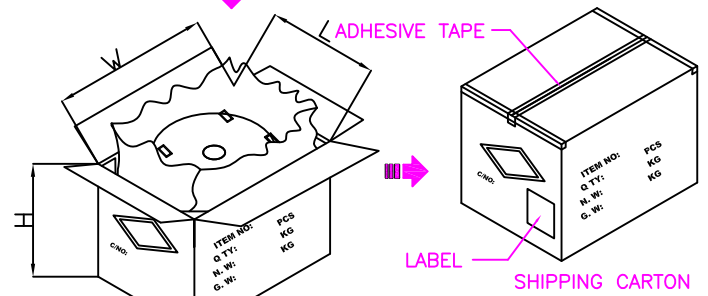
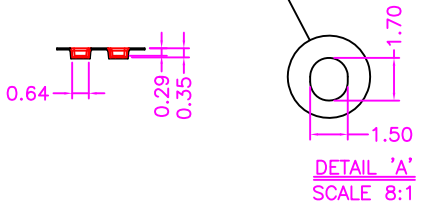
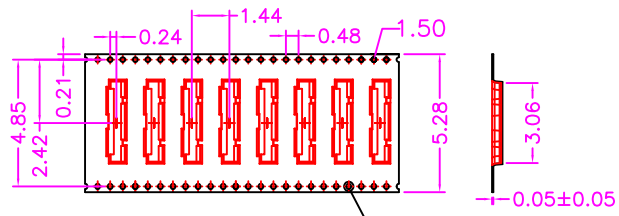
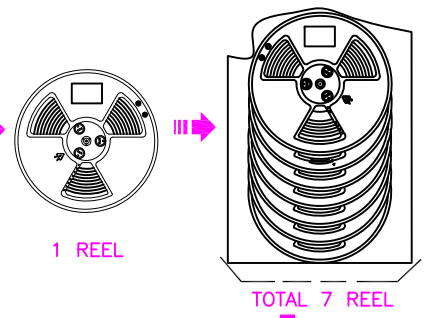
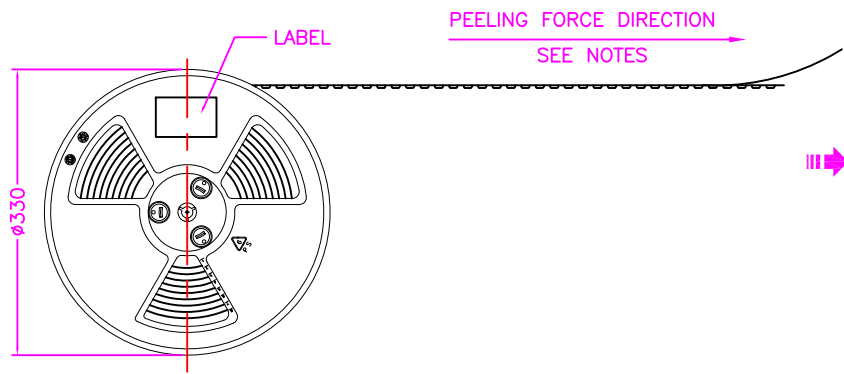

Cyberconn Technology Co., Ltd. www.cyberconn.com.tw Tel:+886-3-4951314						
TOLERANCES		TITLE				
X.X ±0.3		LVDS CONNECTOR SERIES				
X.XX ±0.2		LVDS, 0.50mm PITCH CONNECTOR, PACKAGE				
X.XXX ±0.1		DRAWN BY	CHECKED BY	APPROVED BY		
Angle ±5°		<i>Janice</i>	<i>Lion</i>	<i>Benson</i>		
		UNIT	SCALE	SIZE	DRAW NO.	REV. Sheet
10001		MM	NONE	A4	2LVAC-001-1	A 1/1

A	RELEASE	2011.7.27
REV.	DESCRIPTION	DATE